

[pro]master®

Camera and Camcorder  
[ *Shoulder Support* ]

**Step 1: Part Identification**

- 1. Shoulder Pad ( x 1 )
- 2. Mounting Frame ( x 1 )
- 3. Bracket ( x 2 )
- 4. Knob ( x 1 )
- 5. Mounting Plate ( x 1 )
- 6. Hand Grip

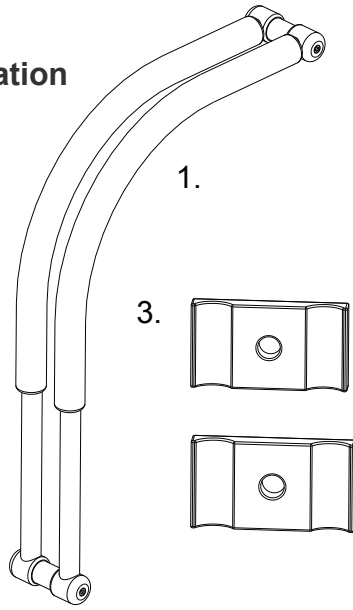

**Assembly Guide**

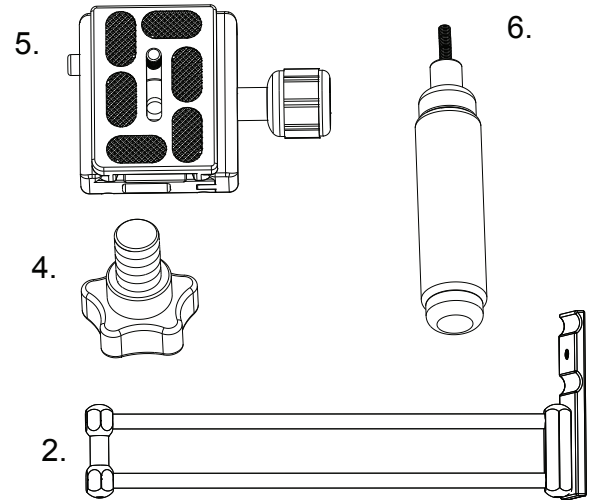

**Step 2**

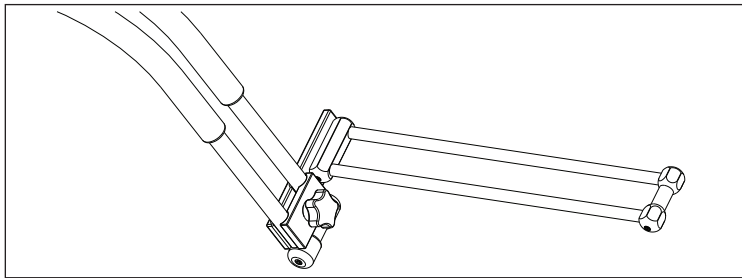

Knob (# 4) through the bracket (# 3) into the should pad (# 1).

**Step 3**

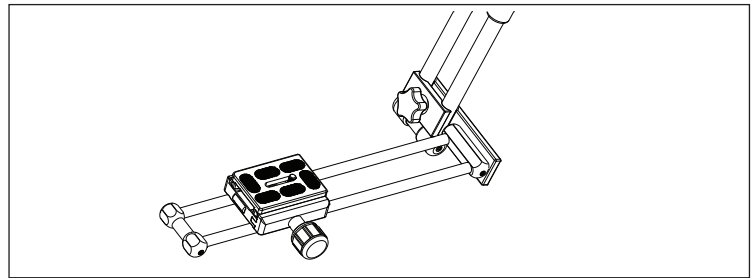

Align the mounting frame (# 2) to the grooves on the mounting plate (# 5).

**Step 4**

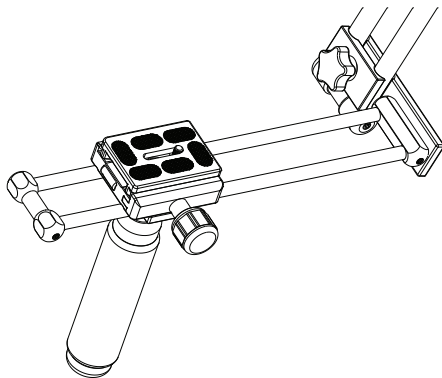

Screw the hand grip (# 6) into the mounting plate (# 5)